

FINISH: P/C SURF MIST

**AP ASSOCIATED PROJECTS** COMMERCIAL BUILDERS,  
PROJECT MANAGERS,  
PLANNERS & DESIGNERS

T 03 8787 3000 F 03 8787 3025  
48-58 Cyber Loop, Dandenong South VIC 3175

Rev	Date	Description

ALL DIMENSIONS IN (mm)  
UNLESS OTHERWISE SPECIFIED  
BREAK ALL SHARP EDGES

TOLERANCES  
(BEFORE PAINTING  
& AFTER PLATING)  
X ± 1.00  
X.X ± 0.50  
X.XX ± 0.10  
ANGLES ± 0.5°

A01- RENDER

CLIENT: NJP

PROJ. NO.: TBA

PART NO.: NJP027

Revision --

Page 1

TOP CAP - SLIMLINE  
W600 x H40

PRODUCT CODE: **NJP027**

Date: 18/12/2024

Drawn by PS

Checked by --

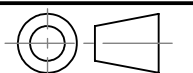

DO NOT SCALE

Scale@A3 1:5

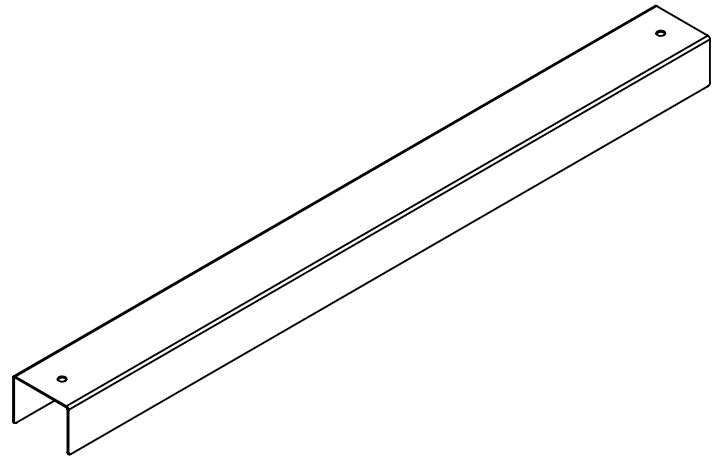

600

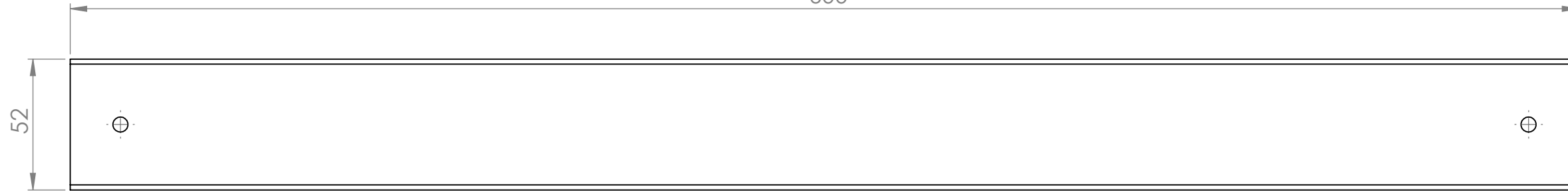

52

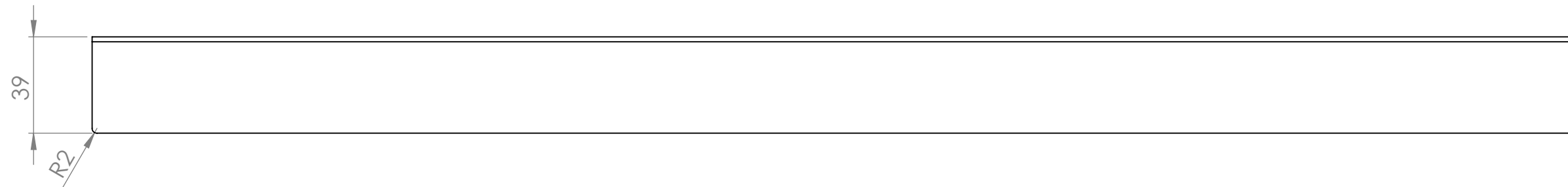

39

R2

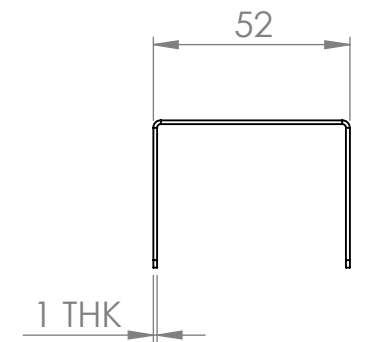

52

1 THK



T 03 8787 3000 F 03 8787 3025  
48-58 Cyber Loop, Dandenong South VIC 3175

Rev	Date	Description

ALL DIMENSIONS IN (mm)  
UNLESS OTHERWISE SPECIFIED  
BREAK ALL SHARP EDGES

TOLERANCES  
(BEFORE PAINTING  
& AFTER PLATING)  
X ± 1.00  
X.X ± 0.50  
X.XX ± 0.10  
ANGLES ± 0.5°

**A02- DIMENSIONS**

CLIENT: NJP  
PROJ. NO.: TBA  
PART NO.: NJP027  
Revision --  
Page 2

**TOP CAP - SLIMLINE**  
W600 x H40

PRODUCT CODE: **NJP027**

Date: 18/12/2024

Drawn by PS

Checked by --

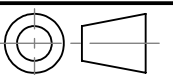

DO NOT SCALE

Scale@A3 1:2